

LITERATURE CITED

1. T. Chang, "Improvement of the profile of electrodes used for creation of a homogeneous field in transverse discharge lasers and other high-voltage equipment," Prib. Nauch. Issled., No. 4 (1973).
2. J. S. Pearson and J. A. Harrison, "A uniform field electrode for use in a discharge chamber of restricted size: design and performance," Brit. J. Appl. Phys., 2, 77 (1969).
3. V. P. Il'in, Numerical Methods for Solution of Electrooptical Problems [in Russian], Nauka, Novosibirsk (1974).
4. M. Ya. Vygodskii, Handbook of Higher Mathematics [in Russian], Nauka, Moscow (1966).

MEASUREMENT OF THE TEMPERATURE OF GAS BETWEEN THE BUSBARS OF A FLAT MAGNETOCUMULATIVE GENERATOR

V. P. Isakov and A. S. Nuzhdov

UDC 621.365:91

The study of air flow between metallic plates colliding with a high velocity (of the order of several kilometers per second) is of great interest in connection with problems arising in the study of processes occurring in magnetic-explosion generators, explosion plasma compressors [1], and in explosion welding [2]. As a result of the collision of the plates, a region of shock-compressed gas (gas plug), which grows in size as the distance from the beginning of the collision increases, is created in front of the moving point of contact. The heated gas should have an especially strong effect on the operation of cylindrical magnetic-explosion generators, since in these generators there is no lateral surface through which gas can flow out.

The gas temperature was measured by the brightness method according to the relative blackening of the photographic film when the source and a standard were photographed simultaneously with a high-speed camera [3, 4]. The standard was a shockwave (SW), excited in a cylindrical channel by detonating an explosive charge, the constancy of whose velocity and brightness temperature was proved in [5].

In the experiments, whose arrangement is shown in Fig. 1, the detonator 1, which detonated the intermediate charge 2, excites a detonation wave in a gas-shaped charge 3, and the plasmoid formed is pushed out into the cylindrical tube 4. The plasmoid moving past the slits 5 is photographed; at the same time, the mirror 6 projects the image of the shock-wave from the end of the tube through the window 7 of the explosion chamber 8 and the stepped attenuator 9 onto the film of camera 10. Then the emission of the gas plug, compressed by the colliding plates, is photographed in the next frame of the film. The arrangement of the experiments on photographing the collision of steel or duraluminum plates, arranged in parallel, is shown in Fig. 2, where the plate 1 with a cross section of 100×2.8 mm was hurled with a 10-mm-thick layer of hexagen 2 into the 80×10 mm plate 3. Before the collision the plates were parallel to one another with the gaps between them. The emission from the shock-compressed gas 4 was photographed through diaphragm 6 and interference filter 7 ($\lambda = 450 \pm 2.5$ nm) with camera 8. In some experiments, a multistep attenuator was used instead of a light filter. In addition (in order to determine the stationariness of the process) the velocity of the point of contact was measured from the difference in the closure of the contacts of the sensors 5 (forming the triggering and stopping signals for the Ch3-33A frequency meter) through a standard triggering circuit. The temperature was determined from the photographs obtained as follows. The velocity of the SW in the cylindrical tube was found from the known distance between the slits and the frame speed, while the temperature was determined from the shock adiabat of air [6]. Knowing the temperature of the standard and the characteristic curve of the film, the temperature of the source can be determined from the degree of blackening of the film.

Krasnoyarsk. Translated from Zhurnal Prikladnoi Mekhaniki i Tekhnicheskoi Fiziki, No. 5, pp. 5-9, September-October, 1986. Original article submitted July 2, 1985.

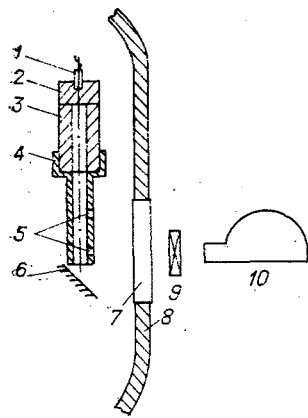

Fig. 1

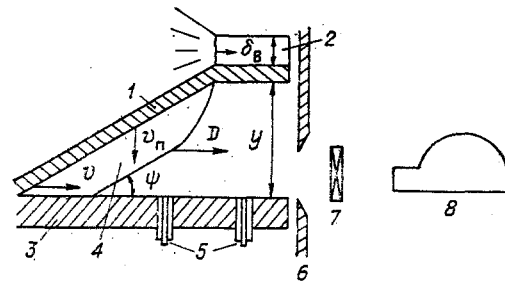

Fig. 2

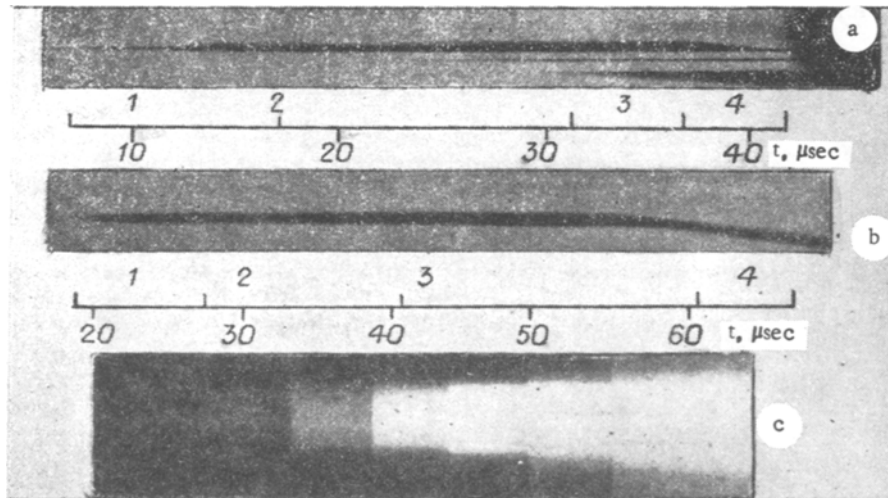

Fig. 3

Typical photographs of the emission of the air between the plates 250 and 400 mm long (a and b), installed with gaps of 10 mm, and also of the standard, photographed through an attenuation, are shown in Fig. 3. The boundaries of the sections with different brightness and the time scale from the start of the collision of the plates are shown at the bottom of the photographs. At first, in section 1, the emission is determined by the nonstationary interaction of the SW in the corner. The collision of the oblique SW with the bottom plate is supersonic and regular, so that when the first shock front is reflected a Mach leg is not formed. A system of oblique reflected SW, whose angle of incidence increases with each subsequent reflection, appears in the corner, so that beginning with some wave the reflection becomes irregular (Mach). The intensity of subsequent waves decreases, which makes it possible to replace in the approximate analysis all waves, beginning with the second, by one wave, but its intensity must now be determined not from the condition of reflection, but from the condition that the mass velocity of the gas behind the front must equal the velocity of the point of contact. A gas plug (section 2) gradually accumulates behind the first SW and finally fills the entire gap and is heated to such an extent that it begins itself to emit as a black body (section 3). The windows in the diaphragm of the top moving plate overlap in section 4. If the plates are long, then the gas plug accumulating between

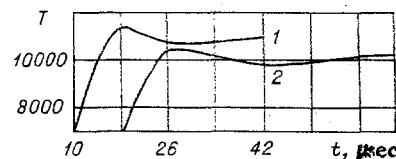

Fig. 4

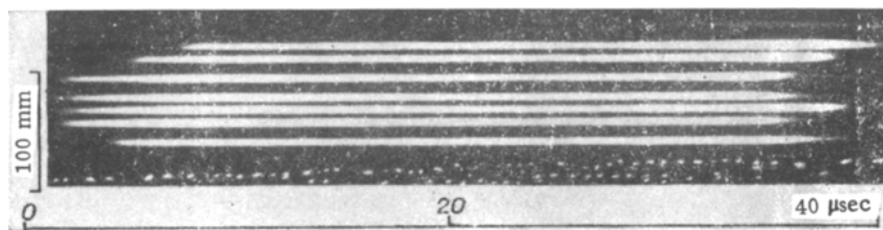

Fig. 5

TABLE 1

$T_{st}, ^\circ\text{C}$	st	$u, \text{m/sec}$	$\rho_g, \text{kg/m}^3$	M	Method	$T_s, ^\circ\text{C}$	$c_p, \text{J}/(\text{g}\cdot\text{deg})$	$\rho, \text{g/cm}^3$	z, m
21 700	$1.8 \cdot 10^{-3}$	7300	14.55	3.27	Al	640	1.04	2.7 2.38	0.18—0.24
					Fe	1400	0.47	7.87 7.2	0.18—0.42
					Cu	1083	0.46	8.93 8.22	1.04—1.5

them is long and interacts with the diaphragm window before the top plate does (section 4 in Fig. 3b).

The time dependence of the brightness temperature, calculated from the photographs, is shown in Fig. 4. Curve 1 corresponds to an experiment with a 10-mm gap and curve 2 corresponds to a 20-mm gap. It is evident that after a gas plug of sufficient size accumulates its brightness temperature remains almost constant and has a magnitude of $\sim 11,000^\circ\text{C}$. For gaps more than 20 mm wide between the plates (for the plate width indicated above) or when the plates are tilted with respect to one another (an initial angle exceeding 7°), the temperature of the plug is much lower ($\sim 4000^\circ\text{C}$), which is comparable to the temperature of the SW front, and the vertical size of the emitting region is smaller than the instantaneous gap width between the plates.

In experiments with long plates (up to 800 mm) a slit, whose image was photographed with the camera through a long tilted mirror placed underneath the slit, was cut in the bottom plate. These experiments showed that even on such long plates the temperature of the heated plug remains constant after the plug has been accumulated and the velocity of the contact point is stationary, but the image of the slit has a pulsating structure which is apparently attributable to the reflection of the light from the wavy surface of the top plate — a phenomenon first observed by Knoepfel et al. [7] and, in addition, after the collision, waves also form on the bottom plate.

We shall estimate the resistance of a gas plug of unit height using the formula $R = (1/\sigma)l$, where σ is the electrical conductivity of air, taken from the tables in [8]. To determine σ , it is necessary to know the density ρ of the gas plug, which can be found from the compression $\kappa = \rho/\rho_0$ (ρ_0 is the normal density) and the shock adiabat of air [6]. The linear size of the gas plug is expressed in the form $l = (D - v)t + l_1$ [9], where D is the component of the velocity of the SW in a direction parallel to the bottom plate; v is the velocity of the gas in the same direction, equal to the velocity of the piston (or the velocity of the point of contact of the colliding plates); t is time; l_1 is length of the plug, which has accumulated up to the moment of contact of the plates: $l_1 = (D - v/\cos\psi) \times y\delta_c/v_p$. Here y is the gap between the plates in units of the thickness of the charge; δ_c is the thickness of the charge; ψ is the angle of incidence of the first SW on the bottom plate; v_p is determined from the one-dimensional layout of the detonation which, for our case, has the value 1.7 km/sec. Thus, $l_1 = 4$ mm. The computed resistance and lengths of plugs of unit thickness are presented below:

$t, \mu\text{sec}$	20	40	60	80	100
l, mm	16	28	40	52	64
R, Ω	0,118	0,067	0,047	0,036	0,029

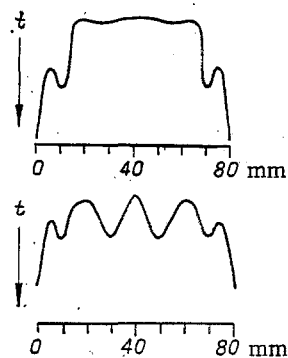

Fig. 6

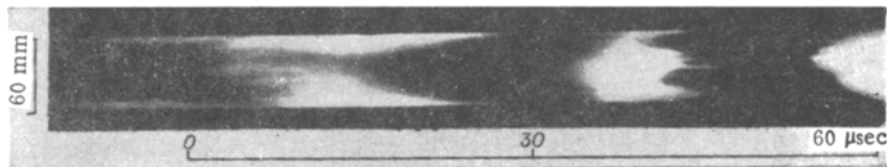

Fig. 7

It is evident that over the operating time of the generator (100 μsec) its resistance is only five times higher than the resistance, for example, of an unshaped generator; i.e., a significant amount of energy can be absorbed in the gas plug, as a result of which the losses of magnetic flux grow.

The effect of the heated gas plug on the walls of the generator and holder causes them to heat up significantly. We shall make an estimate as follows. The heat flux q from the gas into the metal in a turbulent flow of gas over the metal is written in the form [10]

$$q = \text{St} \rho_g u c_p (T_{\text{st}} - T_s) + \sigma T_{\text{st}}^3 (T_g - T_0), \quad (1)$$

where T_{st} is the stagnation temperature, determined in the standard manner: $T_{\text{st}} = T_g [1 + (\gamma - 1)M^2/2]$; Stanton's number $\text{St} = 0.125 [2 \ln(a/k_i) + 1.74]^{-2}$; if it is assumed that the properties of the metal do not change with the transition into the liquid state, while the parameters of the gas in the plug remain constant right up to the point of contact; T_s , T_g , ρ_s , u , c_p , γ , σ , a , k_i , and M are the temperature of the surfaces of the plates and of the gas, the density, the mass velocity behind the SW front, the specific heat capacity, the adiabatic index, the Stefan-Boltzmann constant, the distance between the plates, the average size of the irregularities on the plates, and the Mach number. Substituting here the experimentally determined gas temperature of 11,000°C, the average size of irregularities of $\sim 10^{-3}$ cm, the width of the gap between the plates 2 cm, and taking the remaining parameters from the shock adiabat of air [6], we obtain the heat flux from the gas into the metal $8.6 \cdot 10^9$ W/m². The determining term in formula (1) is the first term; it is more than two orders of magnitude greater than the second term.

The heat flux from the gas, assuming that it is constant, heats the surface of the plates of the holder and the busbars according to the law [11] $T_s = (q/2\lambda) \cdot \sqrt{6\lambda/c_p\rho} + T_0$, while its effective duration equals $t = \ell/u\kappa$, where λ is the thermal conductivity. From here it is possible to obtain an expression for determining the distance over which the walls of the holder and the busbars are heated to the melting temperature:

$$Z = u\kappa c_p \rho / 6\lambda [2\lambda(T - T_0)/q]. \quad (2)$$

The estimates obtained using (2) with the value of the heat flux indicated above are presented in Table 1, where the thermophysical properties of the metals correspond to their normal state and the state close to the melting point. It is evident from the tables that the walls of the holder and the busbars can be heated to the melting temperature at distances from the beginning of the collision of the order of a meter or less. In our opinion, this gives rise to the formation of microirregularities because of the channel instability, the appearance of strong gradients of the electric field around irregularities, and breakdown. Moreover, it is obvious that the generator must be carefully prepared and its walls must

be polished. In this case, the irregularities are small and, therefore, St is small, which leads to a lower heat flux and less intense heating of the holder and busbars.

To determine the form of the emitting surface and the temperature distribution over the width of the plates, we performed a series of experiments with plates turned around the axis by 90° and with a perforated protective screen. A photograph from one of these experiments is shown in Fig. 5, and the form of the emitting surface at the start and end of the collision is shown in Fig. 6. The temperature in the gap is approximately constant over the width of the plates and equals $11,000^\circ\text{C}$.

The possible formation of microjets consisting of the material of the plates from the corner of the collision was cut off by placing between the plates a piece of thin transparent plastic. In this case, the brightness temperature turned out to be somewhat lower ($\sim 9000^\circ\text{C}$), and its distribution along the length had a pulsating character, which is clearly seen in Fig. 7.

LITERATURE CITED

1. A. E. Voitenko, "Strong shock waves in air," *Zh. Tekh. Fiz.*, No. 1 (1966).
2. V. M. Kudinov and A. Ya. Koroteev, *Explosive Welding in Metallurgy* [in Russian], Metallurgiya, Moscow (1976).
3. I. Sh. Model', "Measurement of high temperatures in strong shock waves in gases," *Zh. Eksp. Teor. Fiz.*, 32, No. 4 (1957).
4. M. A. Tsikulin and E. G. Popov, *Emissive Properties of Shock Waves in Gases* [in Russian], Nauka, Moscow (1977).
5. G. V. Pryakhin, V. M. Titov, and G. A. Shvetsov, "Investigation of high-velocity gas flows by the electromagnetic method," *PMTF*, No. 3 (1971).
6. N. M. Kuznetsov, *Thermodynamic Functions and Shock Adiabats in Air at High Temperatures* [in Russian], Mashinostroenie, Moscow (1965).
7. H. Knoepfel, H. Kroegler, et al., "Generation and switching of magnetic energies in the megajoule range by explosive systems," *RSI*, 40, No. 1 (1969).
8. N. I. Kalitkin, L. V. Kuz'mina, and V. S. Pogov, "Tables of thermodynamic functions, shock adiabats of air, and transport coefficients of plasma," Preprint, Inst. Applied Mechanics (1972).
9. S. N. Ishutkin, V. I. Kirko, and V. A. Simonov, "Study of the thermal effect of shock-compressed gas on the surface of colliding plates," *Fiz. Goreniya Vzryva*, No. 6 (1980).
10. S. I. Anisimov and Ya. A. Imas, *Action of High-Power Radiation on Metals* [in Russian], Nauka, Moscow (1976).
11. B. A. Uryukov, "Theory of erosion of electrodes in nonstationary spots of an arc," *Izv. SO Akad. Nauk SSSR, Ser. Tekh. Nauk*, No. 8 (1975).